

Synchron 3

models: P039 YN A4S M1
P038 YN A4S M1
P037 YN A4S M1

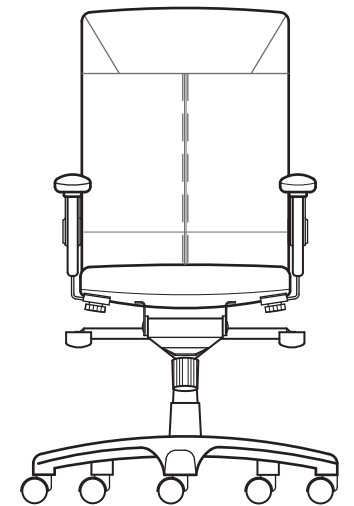
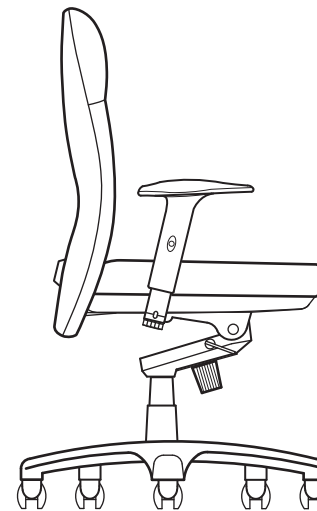

User Instructions

MERRYFAIR®

A **Seat Height Adjustable**
Flip up lever on right-side to raise or lower seat. Adjust such that your feet are adequately supported on floor.

B **Multi-Position Tilt Lock**
Recline to desired position, and flip down lever on left-side to lock. Flip up lever to release tilt-lock.

C **Tilt tension Control**
Turn bottom knob clockwise to provide a stronger tilt tension, and vice-versa. Adjust such that minimum effort is required to push back when recline.

D **Backrest Height**
Turn the knob anti-clockwise to loosen the backrest and adjust the backrest so that the backrest curvature follow the curve of your back. Then turn the knob clockwise to tighten the backrest.

E **Armrest Width**
Turn bottom knob clockwise to loosen the armrest and adjust inwards or outwards to suite your shoulder width.

F **Armrest Height**
Press the button and raise or lower the armrest. Adjust height to adequately support elbows to take strain off shoulders.

G **Armrest Depth**
Grasp armpads and push them forwards or backwards to suit your arm support.

H **Armpad Angle**
Grasp armpads and rotate them inwards or outwards to adjust elbow support to suit specific tasks. An inward position works during keyboard use, while an outward position is recommended during mousing.

Synchron 3

models: P039 YN A4S M1
P038 YN A4S M1
P037 YN A4S M1

