

MERRYFAIR®



# VELO

Seating Products

## **Seating Excellence at Work**

The Velo product family offer four models in the range to meet different needs and budgets in a workplace.





**Backrest Height**

Medium backrest with headrest, medium backrest and low backrest. All comes with our charcoal color back cover.

**Armrest**

Standard or soft PU foam pad with three dimensionally adjustable or non adjustable fixed armrest.

**Type of Upholstery**

Seat and backrest covered in leather or synthetic covering for premium model or seat covered with fabric and backrest covered with the mesh fabric for standard model.

**Mechanism**

Standard synchronized mechanism features 3-position tilt lock, pneumatic seat height and auto weight-sensing tilt tension.



Velo offers three backrest heights, two types armrests and two types of upholstery.

### Headrest

Fixed Cushion Headrest, consists of 38mm extra soft sponge to give optimal support to the user.

### Polyester Mesh

Provides elastic support, yet allowing ventilation for airy comfort.

### Armrest

Come with 3-way armrest adjustable for height, depth and swivel angle. Armpad in black, of molded polyurethane with steel insert. The armrest molded by black fiber-filled nylon (100% recyclable).

### Base

350mm Five-strong base of diecast aluminium alloy (100% recyclable) in polished finish. 50mm dual-wheel castors of moulded polyamide (nylon).

### Backrest

Black outer shell, grey inner shell, supported by a aluminium backbone in polished finished. The back frame made by black polypropylene (100% recyclable)

### Mechanism

A weight-sensing mechanism auto-adjusts recline resistance according to user weight. Provides 3-position Tilt-Lock, Seat Height and Seat Depth Adjustment.



**Swivel-Tilt chair  
with headrest  
899 YM A69 VP**

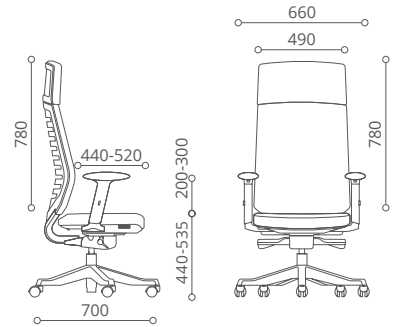

**Swivel-Tilt chair  
898 YM A69 VP**

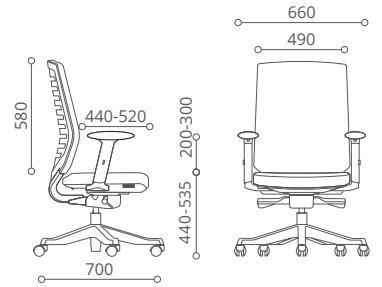

**Swivel-Tilt chair  
897 YM A69 VP**

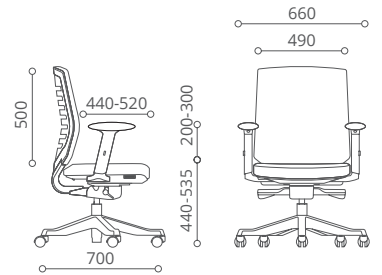

**Visitor chair  
891 NA A15 B**

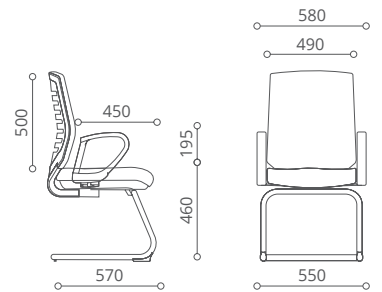

Synchronized Mechanism



Height Adjustable Armrest



Pneumatic Seat Height Adjustable



Depth - Angle Adjustable Armpad  
2-way adjustable armpad

## Velo: Options

### Armrest



3-Way Adjustable Armrest  
with PU Ampad  
(A69)



Fixed Armrest  
(A15)

---

### Base



350 Polished  
Aluminium Base  
(VP)



350 Studio Base  
(N2)



Cantilever Base  
(B)

## HEAD OFFICE & FACTORY

[www.merryfair.com](http://www.merryfair.com)

### Merryfair Chair System Sdn Bhd

(Co. No. 86276-A)  
No.2, Jalan Koporat 1/KU9,  
Taman Perindustrian Meru,  
42200 Klang, Selangor D.E., Malaysia.

### International Sales & Marketing

Tel. +603 3393 2888  
Fax. +603 3393 2000  
[enquiry@merryfair.com](mailto:enquiry@merryfair.com)

### Domestic Sales & Marketing

Tel. +603 3393 6868  
Fax. +603 3393 6888  
[domestic@merryfair.com](mailto:domestic@merryfair.com)

## SHOWROOM OFFICE

### Merryfair Marketing Sdn Bhd

(Co. No. 665054-V)  
No. 82-84, Jalan 2/23A,  
Jalan Genting Kelang,  
53300 Kuala Lumpur, Malaysia.  
Tel. +603 4149 8899  
Fax. +603 4143 0113

## REGIONAL OFFICE & SHOWROOM

### 美力菲 (中国) 家具有限公司

广东省佛山市顺德区容桂华口顺德高新区(容桂)华天路21号  
邮编: 528306  
Merryfair (China) Co.,Ltd  
No. 21, Huatian Road, Shunde High Tech Industrial Zone  
(Ronggui), Huakou Community, Ronggui Subdistrict,  
Shunde District, Foshan City, Guangdong, China 528306.  
Tel. +86 757 2636 9861  
Fax. +86 757 2881 9700  
[domestic@merryfair.com.cn](mailto:domestic@merryfair.com.cn)

### Merryfair (Singapore) Pte Ltd

33 Ubi Avenue 3, #01-52/53 Vertex,  
Singapore 408868.  
Tel. +65 6284 9098  
Fax. +65 6284 9028  
[enquiry@merryfair.com.sg](mailto:enquiry@merryfair.com.sg)

### Merryfair (Thailand) Co.,Ltd.

19/1-2 Sithakarn, Soi Chidlom  
Lumpini, Pathumwan  
Bangkok 10330 Thailand  
Tel : +66 2254 1588  
Fax : +66 2254 1585  
[sales@merryfair.co.th](mailto:sales@merryfair.co.th)

