

MERRYFAIR®



MOBBY

Seating Products



Customisable Foldable Chair

Mobby is lively, mobile and unpretentious little fella with a colourful personality. You can easily move it around for an impromptu breakout session, or store them away when you need the space for something else. Eye-catching mesh-like shells in popular colour options gives a smart look to suit all venues, from seminar rooms to cafeteria. Its versatile enough to suit educational, teaming and conference applications.



Mobby's versatility is great enough to suit educational, training and conference applications.

Environmental

Almost all components (up to 96% in 641FDA64H4) can be easily disassembled using normal tools and separated into 100% recyclable materials (PP, aluminum, steel). Recycled material content is also used in manufacture where possible (up to 25% for 641FDA64H4). No PVC is used.

Safety & Durability

Mobby is designed and certified to BIFMA X5.1:2002 standards for durability and safety.



Quality Specifications

Perforated-design back shell and seat shell of polypropylene in 4 standard colour options. Optional upholstered seat or back padding will use shells in black colour.

Back frame and seat frame of polypropylene in Black. Optional upholstered seat and back padding in fabric, leather or vinyl on 20mm polyurethane foam. Worn out pads can be replaced on site, using a common screwdriver. Frame and legs of 25mm diameter tubular steel in silver epoxy powder-coat. Armcaps of polypropylene in black colour. Tablet shell in black ABS. Tablet mechanism of diecast aluminum in black powder-coat finish. Polypropylene 5-star base in Black colour. 50mm diameter dual-wheel Castors in black polyamide.

4-leg With Castor

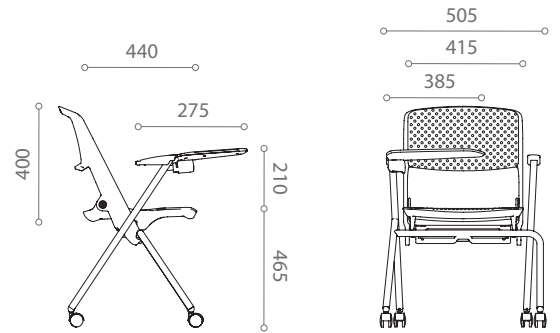

4-leg With Stud

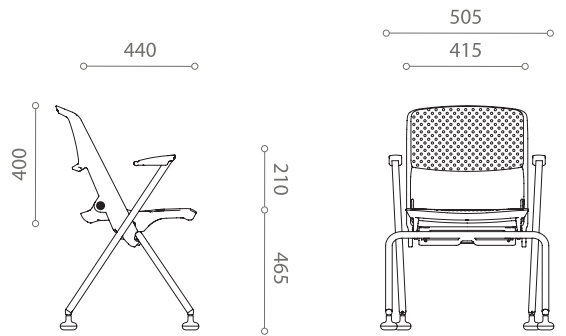

Swivel Base With Gas-Lift

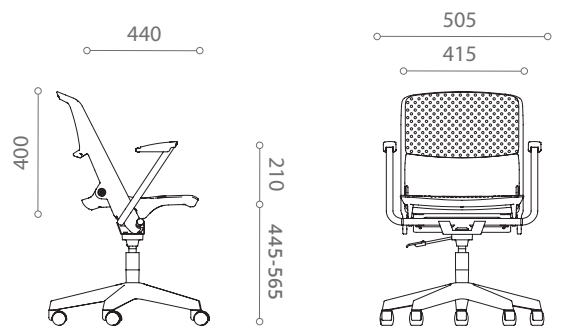

Stacking Pitch

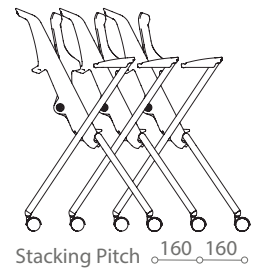

Frame Option

4-leg with Castor



Without Armrest
64_FD A00 H4



With Right Arm & Tablet
64_FD WR1 H4



With Armrests
64_FD A64 H4



With Arm & Tablet
64_FD AW1 H4

Frame Option

Swivel Base With Gas-Lift



Without Armrest
64_FD A00 N3



With Right Arm & Tablet
64_FD WR1 N3



With Armrest
64_FD A64 N3



With Arm & Tablet
64_FD AW1 N3

Seat & Back Options

Plastic Seat

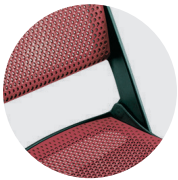

Plastic Back
641_FD A00 H4

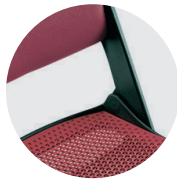

Padded Back
642_FD A00 H4

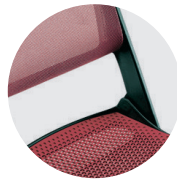

Mesh Back
643_FD A00 H4

Seat & Back Options

Padded Seat

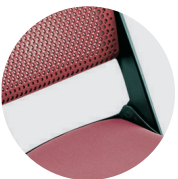

Plastic Back
644_FD A00 H4

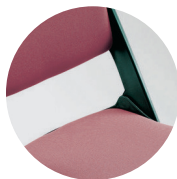

Padded Back
645_FD A00 H4

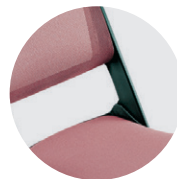

Mesh Back
646_FD A00 H4

Mobby: Options
PP Shell Colour

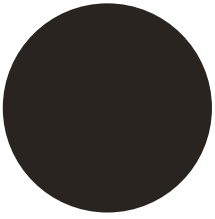

Black
(B)

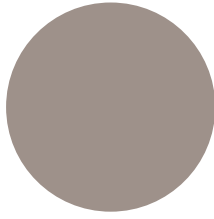

Taupe
(T)

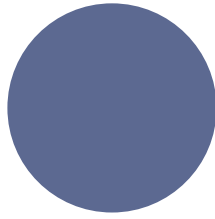

Blue
(U)

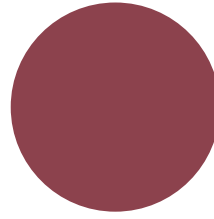

Burgundy
(D)



HEAD OFFICE & FACTORY

www.merryfair.com

Merryfair Chair System Sdn Bhd
(Co. No. 86276-A)
No.2, Jalan Koporat 1/KU9,
Taman Perindustrian Meru,
42200 Klang, Selangor D.E., Malaysia.

International Sales & Marketing
Tel. +603 3393 2888
Fax. +603 3393 2000
enquiry@merryfair.com

Domestic Sales & Marketing
Tel. +603 3393 6868
Fax. +603 3393 6888
domestic@merryfair.com

SHOWROOM OFFICE

Merryfair Marketing Sdn Bhd
(Co. No. 665054-V)
No. 82-84, Jalan 2/23A,
Jalan Genting Kelang,
53300 Kuala Lumpur, Malaysia.
Tel. +603 4149 8899
Fax. +603 4143 0113

REGIONAL OFFICE & SHOWROOM

美力菲 (中国) 家具有限公司
广东省佛山市顺德区容桂华口顺德高新区(容桂)华天路21号
邮编: 528306
Merryfair (China) Co.,Ltd
No. 21, Huatian Road, Shunde High Tech Industrial Zone
(Ronggui), Huakou Community, Ronggui Subdistrict,
Shunde District, Foshan City, Guangdong, China 528306.
Tel. +86 757 2636 9861
Fax. +86 757 2881 9700
domestic@merryfair.com.cn

Merryfair (Singapore) Pte Ltd
33 Ubi Avenue 3, #01-52/53 Vertex,
Singapore 408868.
Tel. +65 6284 9098
Fax. +65 6284 9028
enquiry@merryfair.com.sg

Merryfair (Thailand) Co.,Ltd
Thai Samut Building
Ground Floor, 163 Surawongse Road,
Bangrak, Bangkok 10500 Thailand.
Tel. +66 2266 3855
Fax. +66 2266 3859
sales@merryfair.co.th

MERRYFAIR reserves the right to introduce modifications and withdraw models for continuous improvements without prior notice.

